

Filtration and Separation

IIoT and Remote O&M



Participants – Hot Topic Hour March 30, 2017

First Name	Last	Company	Email
Ravi	Menon	42TEK	ravi_menon_us@yahoo.com
Cameron	Rapoport	AW Chesterton	rapopoc@chesterton.com
Brad	Ellis	Crane Company	bellis@craneco.com
Mary Jo	Surges	Eaton	maryjosurges@eaton.com
Chris	Schottler	Eaton	chrisw.schottler@eaton.com
Tinh	Phan	Emerson	tin.phan@emerson.com
Jayesh	Doshi	eSpin	jdoshi@espintechnologies.com
Sandy	Vasser	ExxonMobil	fgvdlv@gmail.com
Diego	Tebaldi	Hee-Duall	dtebaldi@cecoenviro.com
John	Goodman	Microdyn-Nadir US	j.goodman@microdyn-nadir.com
Aakash	Evans	MnM	aakash.evans@marketsandmarkets.com
Adnan	Sadikot	N/A	asadikot@gmail.com
Enrique	Herrera	OSISoft	eherrera@osisoft.com
Ash	Vallampati	Rexnord	ash.vallampati@rexnord.com
David	Woods	Rexnord	david.woods@rexnord.com
Caroline	Howard	Rotork	caroline.howard@rotork.com
Andre'	Ogino	Schneider Electric	andre.ogino@schneider-electric.com
Jeremy	Freeman	Solv7, LLC	jtf621@fastmail.com
Jim	Cummings	U.S. EPA	cummings.james@epa.gov

Overview



Filtration and Separation IIoT and Remote O&M

- Filtration and separation involves many variables. The applications are frequently critical to successful manufacturing of products and delivery of clean water.
- The Industrial Internet of Things (IIoT) empowered by the Industrial Internet of Wisdom (IIoW) will have a \$10 billion impact on the market size by 2026 and will divert another \$10 billion from traditional market routes.
- Sales of filtration and separation equipment and consumables will exceed \$95 billion in 2026. Of this total \$20 billion will be attributable to the impact of IIoT and Remote O&M.



Filtration & Separation IIoT & Remote O&M Market

Filtration & Separation IIoT & Remote O&M Market	
Segment	\$ billions
Traditional Route to Market	75
New Route to Market	10
New Smart Revenues	10
Total	95
IIoT Impacted Market	20



Some Industries already moving Forward

- There is already a substantial market in certain industries such as oil and gas, pulp and paper, and food processing. The IIoT & Remote O&M segment of the market will be growing by 13% per year over the next decade compared to just 3% for the rest of the industry.
- There has been a great deal of analysis relative to the convergence of information technology and operations technology. Smart sensors, open platforms and improved data analytics are creating the equivalent of millions of continually updated white papers on the performance of individual components, sub systems, and systems. The use of subject matter experts has typically been addressed without regard to the importance of innovation.
- This avalanche of white papers is going to justify an army of experts each able to focus on a very narrow niche. It is also going to dictate interconnection between individuals at each plant within the organization operating the filtration and separation systems. It is going to dictate interconnection between the end users, associations, and suppliers to an extent commensurate with the increase in available knowledge.
- This interconnection is occurring partly through acquisitions. Suez is purchasing GE Water. It has a remote monitoring center in France. It also owns and operates municipal water and wastewater plants throughout the world. It is operating 40% of the municipal plants in Chile. It can monitor centrifuge performance and then add GE Betz chemicals to improve dewatering from the remote monitoring center.
- Some industries can light the way for others. Andritz automation has created FiberVision and can remotely measure particle size of the fibers in the pulp slurry in a pulp and paper mill. The system measures other parameters in all the processes and provides guidance for the operators. Andritz is also offering predictive control algorithms to better operate thickeners, flotation devices, and filters in mining applications

Many Suppliers are moving into Smart Products

- A number of centrifuge suppliers have comprehensive monitoring and control systems. GEA has Wewatch®. Centrisys remotely monitors 32 key operating parameters and offers to log in and make non-critical adjustments to help optimize the process. Alfa Laval Octopus monitors and controls all aspects of the dewatering process.
- A number of the filter vendors are moving forward aggressively in the IIoT space. Mann & Hummel has a new IIoT laboratory in Singapore where it has 10 projects in the pipeline. Donaldson remotely monitors bulk filtration systems for fuel. Restaurant Technologies monitors fryer filter health in restaurants. Aqua Clear monitors RO and nanofilter systems for industrial and commercial facilities. The Evoqua Wallace & Tiernan division has extensive process monitoring systems with intelligent visualization.
- There has been a move to higher efficiency filters for gas turbines. The increased filter cost is justified by lower maintenance. AAF combines remote monitoring with a maintenance package including inventory management. This comprehensive approach provides an opportunity to provide the lowest total cost of ownership.
- There are some power generation companies operating hundreds of gas turbines. One company with a large number of gas turbines is BHE Energy. Mcilvaine has created a beta site to demonstrate the value of IIoT to empower IIoT. BHE also has coal fired plants and wind turbines. So it would have thousands of lubrication systems. A new kidney shaped filter at one of their plants has proved superior in a pulverizer application. Cuno string wound filters are specified at most of their plants but due to particulate contamination related to air cooling the condensate filter needed to be replaced at one plant with a Pall 25-micron filter. When case histories and the knowledge of the plant operators and suppliers are pooled for a company such as BHE, the impact of IIoT becomes more cost effective.



Relative Market Size by Segment

Large

Medium High

Medium Low

Small

Residential/ commercial	mobile	Healthcare	Power	Sanitary/ clean tech	energy	Water /wastewater
Single family	Passenger vehicle	hospitals	Stationary diesel	Food	Oil and gas extraction	Municipal drinking
Multiple family	Trucks	Dental offices	Gas turbines	pharmaceuticals	Oil and gas transport	Rural drinking water
Government /defense	Off road	Outpatient care	Coal fired	Animal research	Gas processing	Municipal wastewater
Retail stores	rail	Medical device	Biomass/WTE	aquaculture	refining	Desalination
Hotels/resorts		Veterinary facilities	nuclear	agricultural	Coal to chemicals	Point discharge wastewater
Office buildings	marine		geothermal	semiconductors	LNG	irrigation
Commercial buildings	aeropsace		hydro	FPD, Memory, other electronics	Oil sands	Flood control

Suez with GE Water is Positioned to be an IIoT Leader

- Suez is acquiring GE Water. This will add the supply of chemicals and a number of water/wastewater products to the Suez suite of turnkey systems and BOO approaches.
- In Chile Suez owns 40% of the municipal wastewater treatment plants. Performance is monitored continuously in a control center in France
- With the GE acquisition Suez can now supply the chemicals and replace some of the typical on site service functions of Betz with remote services. It can also monitor membrane and cartridge health and provide global sourcing.
- GE has industrial expertise to compliment Suez municipal strength. Although GE water will no longer be a part of the very aggressive GE IIoT program it will have the benefit of the experience to date.
- For many filtration and separation suppliers this will represent a new competitive threat which will be even greater if Suez seizes the IIoT opportunity.

GE and Suez Degremont Synergies

- Degremont Technologies—Anderson offers proven expertise in the design, engineering, manufacturing and commissioning of industrial water treatment systems. With more than 3,000 installations in 40 countries, Anderson systems are applied in some of the world's finest power plants, refineries, chemical production facilities, pulp and paper mills, food and beverage production, pharmaceutical and a variety of manufacturing facilities.
- Key capabilities include custom engineered solutions, pre-engineered standard equipment, process optimization, packaged water treatment systems, start-up and commissioning, remote monitoring, and long-term service and customer support programs. Anderson Water Systems applies technologies such as reverse osmosis, EDI, ion exchange, degasification, clarification, and filtration.
- This system capability will be complimentary to many of the GE Water product divisions

Suez already has Remote Monitoring Center

Digital technology is a powerful driver in responding to the environmental challenges faced by local authorities. To support them in this endeavor and to enhance the performance of their water and sanitation services, Suez Environnement opened a monitoring center in Le Pecq (Yvelines, northern France) for all of its remote meter reading and Smart Water infrastructures in France and overseas. These include intelligent management solutions for sanitation as well as water facilities

The Smart Operation Center is the first facility of its kind to continuously monitor the infrastructures of remote meter reading networks (for water, gas, etc.) and Smart Water solutions on a global scale. These solutions are based on the infrastructures for IT and telecommunications (software, servers, user portals, etc.), which must be monitored in order to ensure their proper functioning.

- The Smart Operation Center guarantees the performance of all of the infrastructures and provides reliable and up-to-date information for local authorities and water operators. This comprehensive monitoring system allows it to detect the signs of any incident as early as possible (leaks, meter failure, falling pressure levels, etc.), alert water services managers and reduce response times in resolving any possible issues.

Andritz Automation provides Remote Monitoring and Control for Pulp and Paper Plants

Andritz Automation instruments, helps operators achieve the best information about their operations. Better information means better control and the resultant benefits.

- Control and measure crucial parameters in key pulping process areas 
- Reduce energy consumption
- Improve frequency of measurement
- Minimize equipment wear and tear
- Achieve more consistent operation
- Produce higher value products

FiberVision is a state-of-the-art online sensor that helps pulp operations reduce specific energy consumption, achieve higher value product, improve frequency of measurement and decrease down time.

Andritz Fibervision Applications in Paper Processes

Typical Fibervision Installation

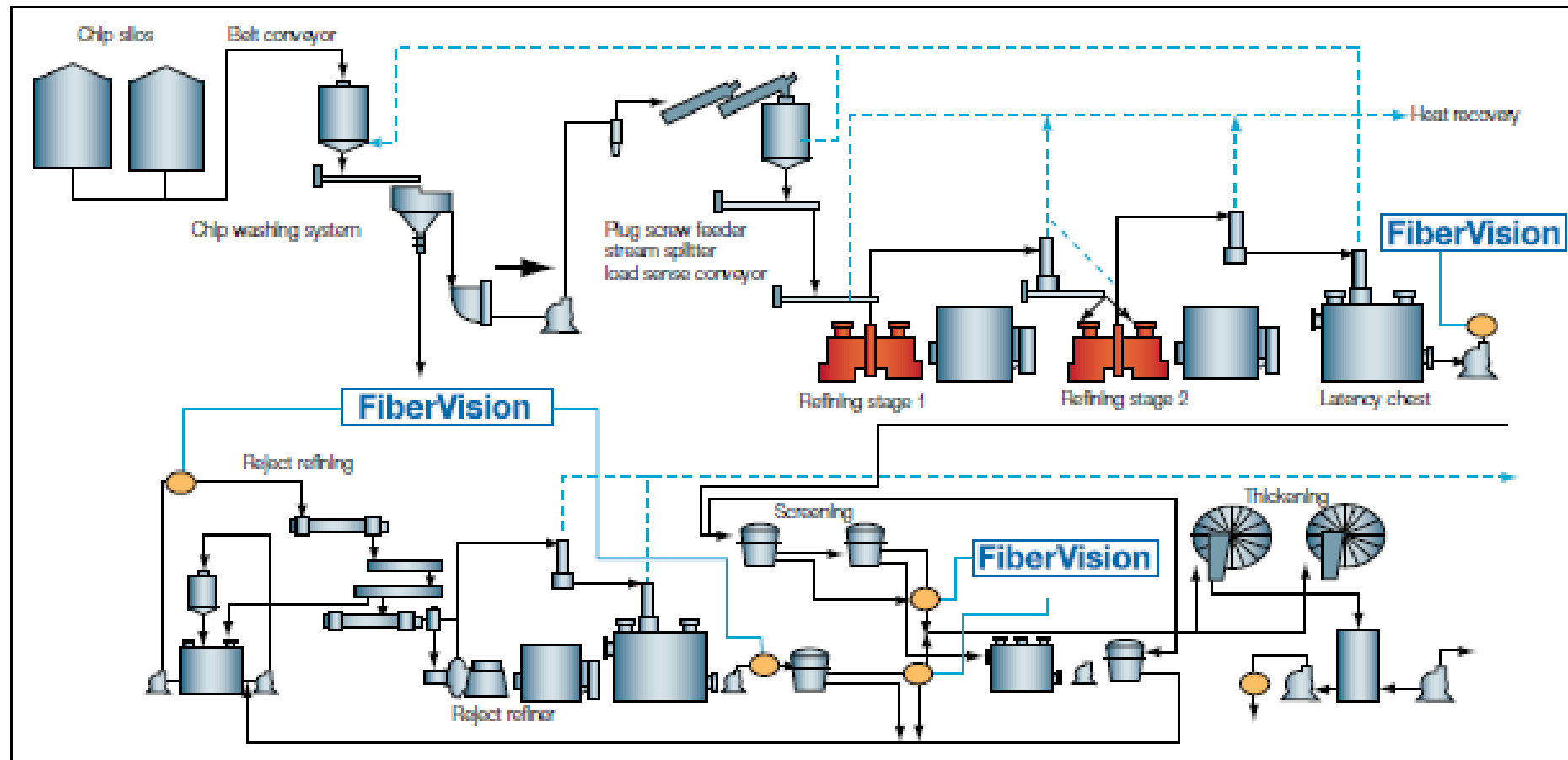

Leveraging Pulp and Paper Filtration Expertise

Fiber property measurements from the FiberVision are used to develop a refiner control algorithm which improves pulp quality and reduces energy consumption. There are many filtration processes where similar analysis of properties will lead to better control and for the monitoring and support of the filter and process suppliers

A very important interconnection in IloW is between industries. The pulp and paper industry has taken the analysis of slurries and filtration to a level far beyond other industries. So these industries can learn a great deal from the pulp and paper achievements

Feature	FiberVision	Competition
Freeness (CSF)/Schopper-Riegler (SR)	✓	✓
Custom drainage indices	✓	x
Fiber morphology (length, width, curl)	✓	✓
Fiber length classification	✓	✓
Fiber length vs. fiber width diagrams	✓	✓
Bauer McNett simulation	✓	x
Shive morphology	✓	✓
Shive enrichment technology	✓	x
Shive classification	✓	x
Specific surface area of pulp	✓	x
Specific surface area of fibers	✓	x
Specific surface area of fines	✓	x
Specific volumes (internal fibrillation)	✓	x
Mat compressibility	✓	x
Vacuum response curve	✓	x
Mat flocculation	✓	x
Mat porosity	✓	x
Prediction of tensile, burst, bulk, etc.	✓	x
Online sampling points	Up to 8	1 to 8
Offline sampling points	12+1	x



Sedimentation & Centrifugation

Sedimentation and Centrifugation is a Robust IIoT and Remote O&M Market

- Due to the rapid development of the Industrial Internet of Things (IIoT) it is clear that there will be a large sedimentation and centrifugation market, but it is less clear who will be the purchasers. Centrifuge manufacturers are well positioned to take a leading role due to the challenging maintenance requirements for this high-speed equipment. Many centrifuge manufacturers already have remote monitoring programs. Centrysis wireless remote monitoring is web-based and tracks 32 key parameters. It includes alerts, reports and service.
- Alfa Laval has several remote monitoring initiatives including decanter centrifuge condition monitoring at the Metropolitan Wastewater Reclamation District of Chicago. Vibration is monitored and controlled through a X20 PLC from B&R Industrial Automation. A custom I/O module has reduced costs and made remote monitoring attractive.
- Alfa Laval has expanded the concept to related remote monitoring and service. The Octopus biosolids dewatering centrifuge autopilot monitors and controls all aspects of the dewatering process. This includes material feed, polymer dosing and internal decanter settings. Infrared sensors analyze performance and automatically make the necessary adjustments.
- GEA is using SAP HANA software as part of a predictive maintenance and service program for food processors. The program also is geared toward optimizing the performance of decanters and separators. The program opens the door to modular service-level agreements, warranted availabilities and insurance for customers.
- A similar program called GEA IO provides remote operation of separators on merchant ships and ferries. Performance on lube oil purification and water treatment is optimized. The operation is seamlessly integrated into the central digital control system for the ship. GEA is pointing to a future of autonomously operated ships. The elimination of the crew reduces operating costs by 20 percent. The first prototypes have already successfully completed test runs. A team of operators remotely monitors operations and if necessary can take control.



Sedimentation & Centrifugation IIoT and Remote O&M Revenues

Sedimentation and Centrifugation Revenues (\$Millions)	
Segment	2026
Centrifuge Equipment	4,000
Service On-Site	1,000
Remote Service and Monitoring	1,800
Sedimentation Equipment	5,800
Service On-Site	940
Remote Service and Monitoring	1,200
Total	14,740

Remote monitoring and service will generate revenues of \$3 billion in 2026. When you add the increased revenues for smart centrifuges and sedimentation equipment IIoT & Remote O&M will create a \$5 billion market.



Model Based Predictive Control Algorithm used for Andritz Thickener in Mining

Thickener density control schematic ▾

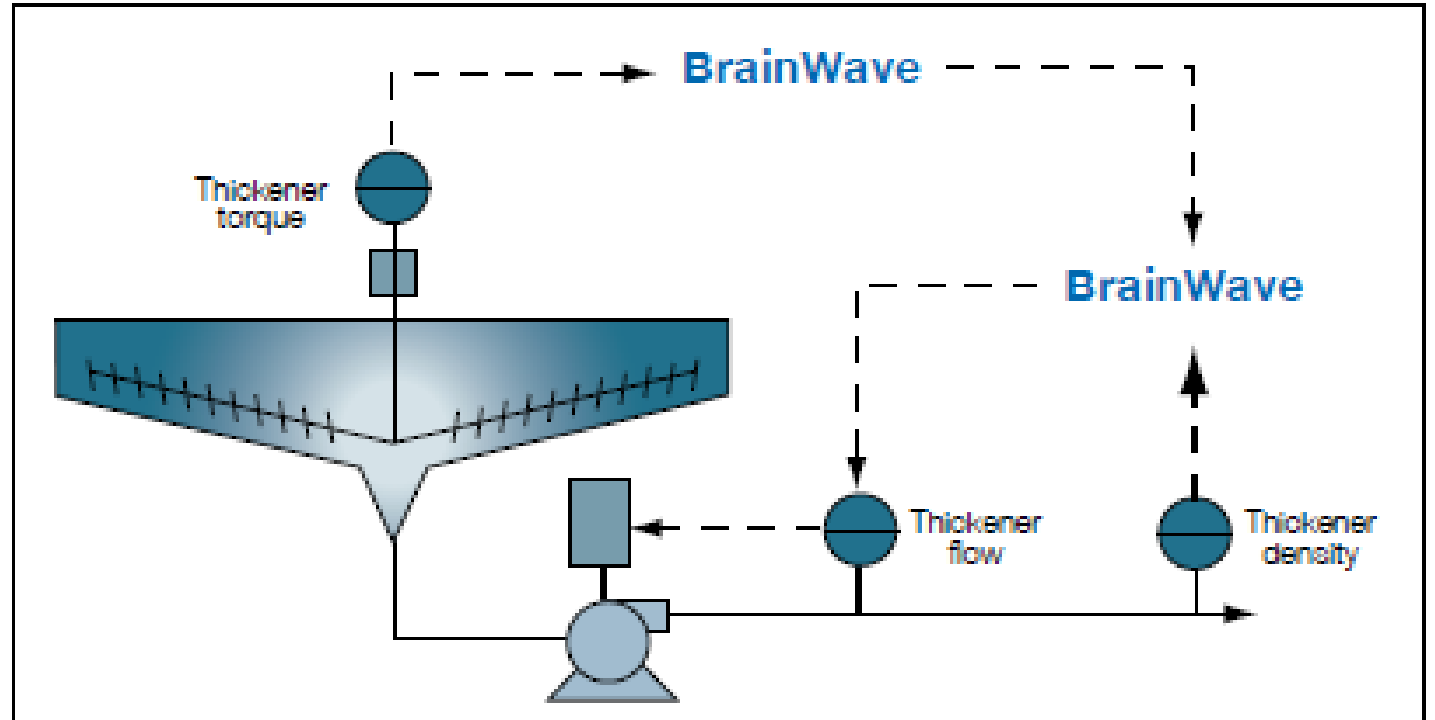

Concentrate thickeners pose a challenging control problem, as both a nominal bed depth and product density must be maintained for proper operation. Using BrainWave, both of these objectives can be satisfied. Bed depth is controlled by monitoring rake torque and making continual adjustments to the target density, within a preconfigured range. In turn, the product density is maintained by varying the pulling rate from the thickener unit.

Conventional controllers struggle with handling the slow dynamics that are inherent in concentrate thickeners. BrainWave, however, is able to account for these slow dynamics due to its model based predictive control algorithm. Dynamics may slowly vary over time, due to such factors as build-up in the thickener vessel. BrainWave accounts for these changes by using its built-in model adaptation algorithm. This algorithm enables BrainWave to adjust its internal model of the process based on real-time observations of the process and to maintain tight control

Flotation Control System from Andritz

BrainWave is a proven control system that stabilizes the operation of all types of rougher, cleaner and scavenger flotation cells, resulting in more efficient operation and improved mineral recovery. BrainWave flotation is a unique control package using patented model-based predictive adaptive control technology, widely used by many primary processing industries. BrainWave is used to maintain the level in each of the flotation cells. By using its model based predictive control algorithm, coupled with its unique integrating control algorithm, BrainWave will reduce the variability in the cell level control so that cell operation can be optimized.

Flotation cell level control schematic ▾

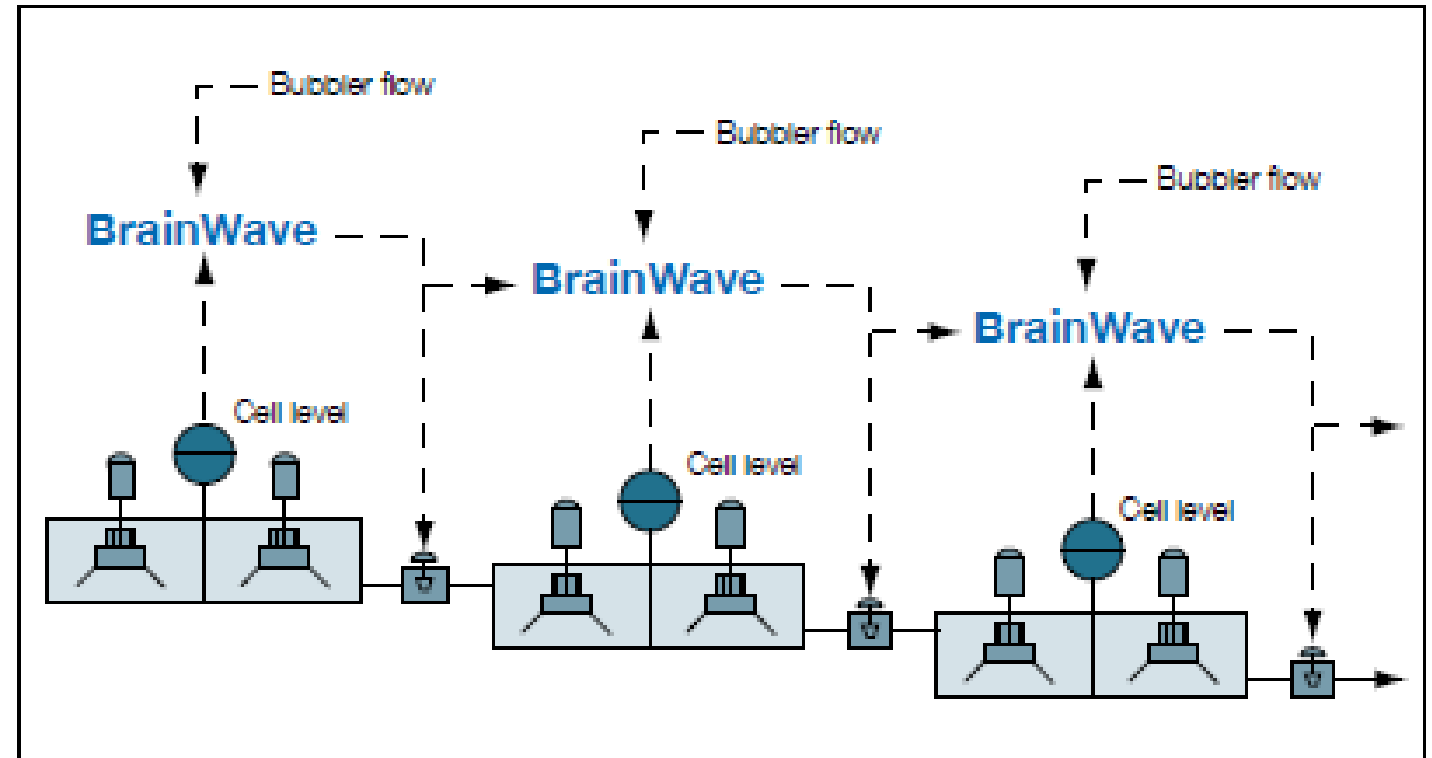

GEA Centrifuge Automation and Remote Monitoring with Wewatch®

- In addition to the company's own compact control units, the S7 control units from Siemens constitute the core item of installation automation. However, components from Allen Bradley, Group Schneider, Mitsubishi, Modicon or Telemecanique can also be used and combined with each other as required.
- The visualization options always ensure optimum user-friendliness. WinCC or Intouch can be used for up to five visualization facilities in the process line, and can also be combined with each other. Whether a simple notification signal or a complex process data exchange arrangement is required: the connection to existing installations or processes via software is nowadays almost obligatory. The specialists from GEA Westfalia Separator Group use the best-known systems such as Profibus DP/PA or Industrial Ethernet as well as additional connections such as DeviceNet, ControlNet or Modbus for this purpose. Fully automatic operation of the installation can also be supported by remote data transfer by means of Internet, modem or GPRS. With GEA Westfalia Separator wewatch®, an independent and comprehensive service concept is available for remote diagnosis.

System Components need to be Monitored

- Level control is fundamental to any sedimentation process. With the advent of microprocessors, ultrasonic technology moved into the level instrumentation mainstream where today it is one of the most common and favored techniques in use at wastewater treatment plants. Many of the characteristics unique to ultrasonics can be managed automatically by signal processing algorithms programmed into each instrument. Today's operators can take successful performance of an ultrasonic instrument for granted assuming the instrument is properly applied and installed.
- The Drexelbrook CCS4000 Multi-Channel Sludge Blanket Level Monitor helps keep track of effluent quality in up to four separate water and wastewater treatment clarifiers and thickeners. The system uses ultrasonic technology to measure the compacted sludge level, the lighter rag material above the interface, and clarity loss in the water above the blanket and rag levels. The monitor eliminates worry about the adverse effects of denitrification, septic sludge, washouts, and mechanical breakdown of rakes. Compacted sludge tracking ensures that only dense sludge is withdrawn from the vessel, reducing pumping and disposal costs. At the same time, the lighter rag layer can be tracked to monitor the settling characteristics of the vessel, and the output can be used to control the use of chemical additives.
- The heart of any clarifier or thickener drive unit is the main gear and bearing. One of the most obvious design features of the DBS drive unit is its torque gauge. DBS has used a large diameter stainless steel gauge that accurately indicates torque in foot-pounds or Newton-meters. The DBS torque gauges can be fitted with 4-20 mA torque transducer for remote monitoring and control. This information allows industrial users to increase the throughput and efficiency of their process.



Centrisys Remote Monitoring System

The entire system is wireless and web-based, so there is no phone or software required, and the data can be accessed from anywhere with an Internet connection. Monitoring includes alerts and daily reports by email or text for:

- Status alarms
- Updates
- Power failure notifications

How Remote Monitoring Works

Remote Monitoring provides real-time text and/or email alerts for any significant system status changes on 32 key operating parameters.

Should your operators need assistance, our team can log in and make noncritical adjustments to help optimize your process. Our remote monitor and control system mimics the centrifuge's local touch screen interface. As a result, very little training is required.

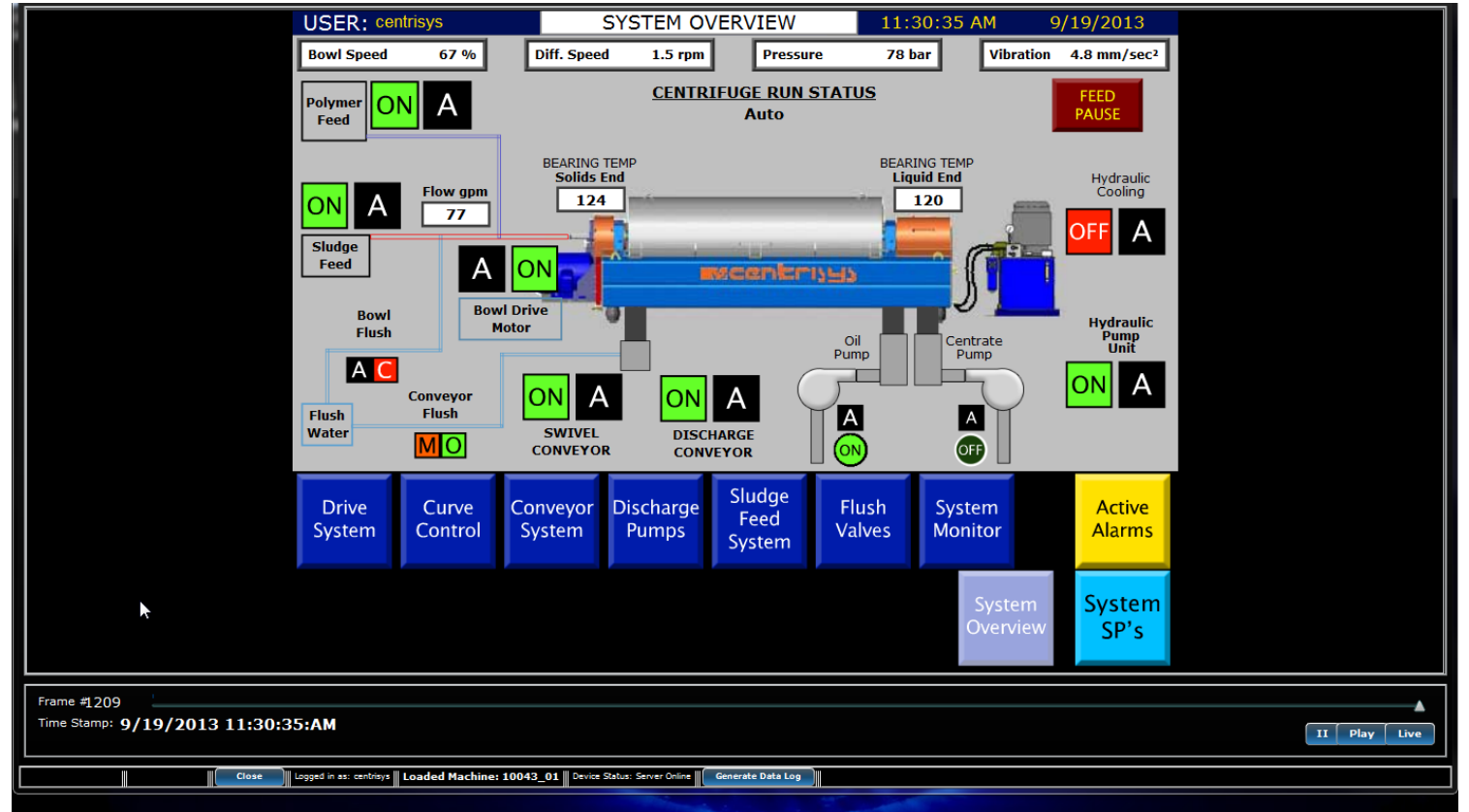

Alfa Laval Biosolids Automated Dewatering

- The Octopus biosolids dewatering centrifuge autopilot from Alfa Laval is custom designed to monitor, control and optimize all aspects of the dewatering process. Software controls material feed, polymer dosing, and internal decanter settings, providing real-time information on each process step. Infrared sensors analyze performance and automatically make necessary adjustments.
- The PLC-based optimization system is integrated with Alfa Laval's 2Touch centrifuge control system. It comes with communication components, remote-access capability, updates and support services.
- The system takes its name from the central control unit and series of tentacle-like sensors. Its key benefit is 24/7 control of the dewatering process and polymer consumption for optimal operation and overall cost savings.

Liquid Filters



Mann & Hummel Developing Smart Filters

- Mann & Hummel launched its first global Internet of Things (IoT) lab in Singapore, where it already has its Asian headquarters. The Fusionopolis Way lab will focus on research and development of commercial, industrial and automotive air filters using smart technologies, such as those making use of advanced sensors and predictive capabilities.
- Work on more than 10 projects is under way, with another 30 in the pipeline, the group said. It aims to double headcount at the lab to 10 employees by next year as it continues to hire system, hardware, firmware and software engineers and data scientists.

Donaldson Remotely Monitors Bulk Filtration Systems

To operate efficiently enough to meet increasingly strict emissions standards, today's sophisticated diesel engines have fuel injection pressures greater than 30,000 psi, which requires cleaner fuel than ever before. Sensitive injectors can be damaged by even the smallest particles, meaning that clean diesel is absolutely essential in all situations. To help meet this need, Donaldson says it has provided equipment owners with the solution to their fuel transfer and storage filtration needs through the use of bulk filtration systems.

By necessity, bulk filtration systems often are located in remote areas and used at all hours of the day or night, especially for critical around-the-clock operations. Tracking pressure drop to know when a filter change is needed can be time consuming, costly and not always practical. Donaldson WaveLength connects to bulk filtration systems and remotely monitors the health of those systems. Custom text and email alerts, coupled to a web interface accessible through any device with an internet connection, allow customers to know when a filter change is required so they can avoid unplanned downtime.

While designed to operate with Donaldson systems, the technology can be fitted to any existing bulk filtration system to monitor the pressure drop.



Remotely Switch Fuel Filters

The Clean Fuels Management DHR Series fuel water separator has a maximum total fuel flow rate of up to 2060 GPH (7,800 L/ph). At maximum flow 99.9% water separation is achieved with approximately 10 times less restriction through a 5 stage filtration process. A small overall footprint, compact design, multiple inlet/outlet configurations allow filters to be installed in many locations and applications where other larger and bulkier filters may not fit. A valve that can switch between filters at full load providing fail safe operation and pointing to the active filter. The push and turn drain valve provides safety and avoids accidents. The DHR Series are preconfigured for the RMS-60 Remote Filter Monitor easy upgrade.



Restaurant Technologies Monitors Fryer Filters

- Restaurant meals should have consistent flavor and quality. The best way to ensure these standards stay high is to implement regular fryer filtration practices. A standard filtration schedule removes contaminants that can affect the color, taste, and smell of food. The Fryer Filtration Monitoring system tracks both frequency and duration of filtration activities.
 - Improves food quality
 - Enhances employee accountability
 - Drives operational consistency across the organization
 - Increases your visibility to actionable information
 - Improves cost management by optimizing oil usage
- Filtration noncompliance alerts are sent when a location has not followed standard operating procedures. This real-time reporting helps operators quickly take appropriate action before customer experience is affected.



Remote Filter Analysis for Condensate Return Filters at Hundreds of BHE Plants

- BHE has filters in ultrapure water, cooling, and wastewater plants. Mcilvaine has set up a site identifying filter successes at some of the 200 installations and has embarked on a comprehensive information gathering program. Here is one example
- Wyodak replaces ACC and selects Pall Filters: This coal-fired power plant used air cooled condensers which caused problems with the condensate. In 2011 PacifiCorp purchased Pall 20 micron filters for the full flow. The question posed at the time was whether it would be worthwhile to use more efficient filters e.g. 10 micron or 6 micron. Five years have now passed since this presentation at the 2011 ACC users group. What is the current status and experience?
- Cuno string wound cartridges are specified as the preferred option for many of the other plants. The air cooling causes particulate contamination and therefore is an additional factor to consider in any analysis of the performance of all the filters
- Global sourcing of condensate filters can be enhanced by continuous monitoring of each filter but only with the wisdom (IIoT) of unique conditions at each plant.
- This global sourcing can also be applied to the lubrication filters as shown on the next slide



BHE has Hundreds of Lubrication Systems which can be Tracked with Condition Monitoring

- The hundreds of lubrication systems in BHE coal, gas, hydro and wind plants can be tracked with cloud based condition monitoring. However, wisdom (IloW) about potential improvements needs to be incorporated for optimum global sourcing. Here is the type of detailed analysis which is needed.
- **New filter for pulverizer lube system:** At the Naughton plant of Pacific Corp an advanced filtration technology for the coal pulverizer was determined to be readily available for heavy gear oil that would meet solve the maintenance problems. An off-line kidney loop filtration package using a high-efficiency, high-dirt-holding capacity, synthetic filter media was procured and installed. The package uses two filter housings mounted in series, with a common-sized element in both housings. The filter elements initially recommended for the trial installation were rated at Beta 25=200 in the first stage and Beta10=200 in the second stage. Oil flow was delivered by a vane pump rated at 10 gallons per minute for a 460 centistoke (cSt) (2,500 SUS) gear oil. Richard Winslow, a niche expert, wrote an article on this and is available to answer questions.



BHE Connect Is An Example Of The Plant Interconnection Needs Of IioW

- Mcilvaine has created a beta site to demonstrate that IIoT, remote monitoring, and global sourcing for any system needs to incorporate wisdom (IIoW).
- IIoW provides the analysis of performance information about operating filters and then the recommendations for innovative steps forward (the kidney shaped filter example on previous slide) and provides technology insights which may affect the decisions (condensate filter performance is dependent on cooling medium).
- The beta site for BHE is explained at [4S01 Berkshire Hathaway Energy Supplier and Utility Connect](#)
- This site connects BHE people at the many plants to each other and to suppliers and consultants
- Mcilvaine also has a LinkedIn discussion group: Power Plant Lubrication
- <https://www.linkedin.com/groups/12021297>



Andritz Brainwave Hyperbaric Filter Control System

One of the main issues in hyperbaric filter control is the over-drying of product, which can increase energy consumption. BrainWave accounts for transport delay times as product moves through the filter to the online moisture measurement sensor. Further improvements to control are possible by monitoring incoming moisture content, either on- or offline, and including this in the control strategy as a measurable feed-forward.

Schematic of moisture control system with BrainWave HB filter

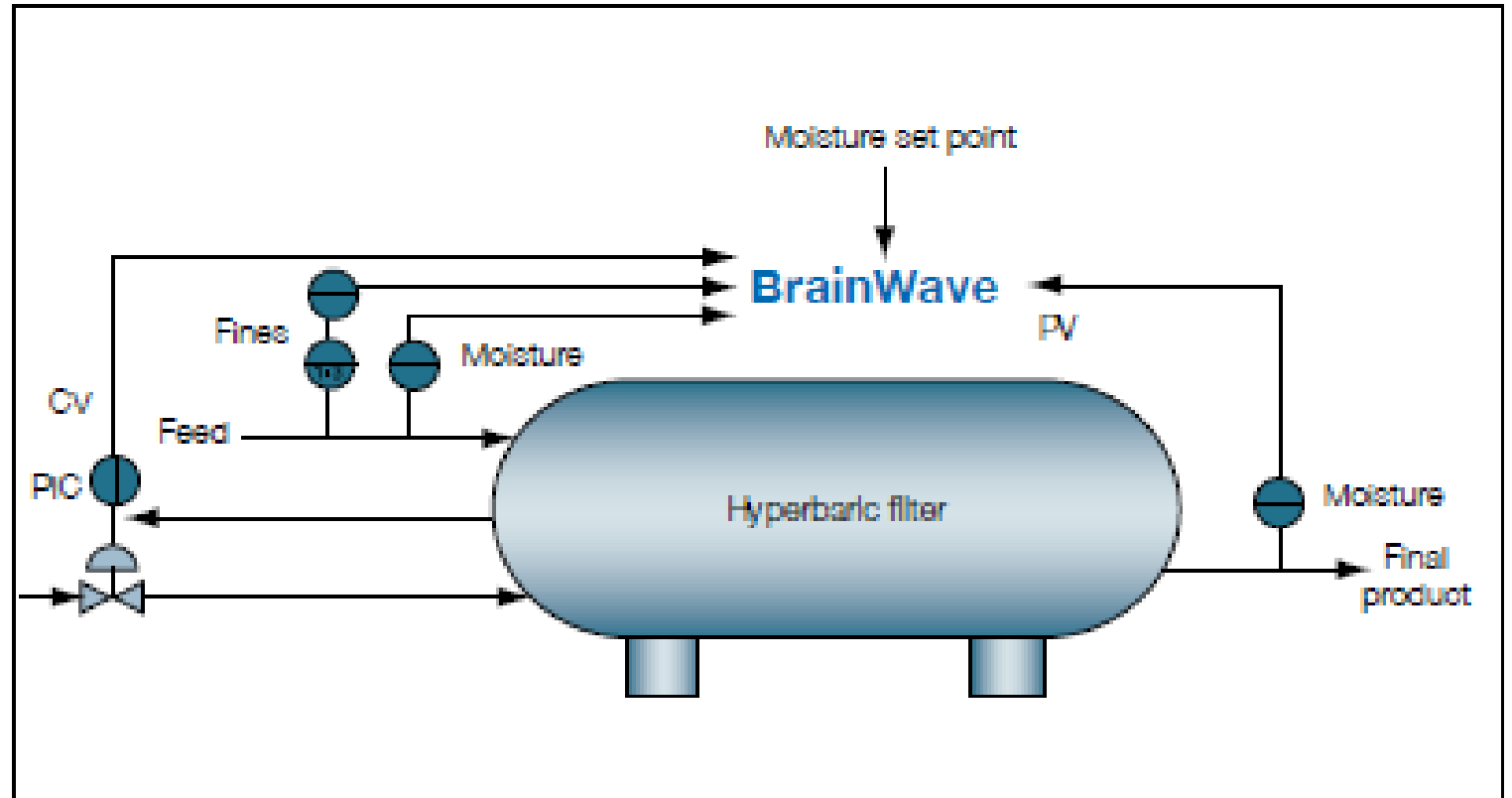

This allows BrainWave to make control corrections as soon as the incoming moisture changes, instead of waiting for the exiting moisture to respond. BrainWave is also able to reduce spikes in air pressure, which cause increased wear and excessive maintenance on equipment. BrainWave accomplishes this by stabilizing the measured moisture content at the filter exit by continuously adjusting air pressure

Remote Monitoring for Reverse Osmosis and Nanofiltration Systems

- Aqua Clear offers Remote Monitoring solutions for Reverse Osmosis (RO) and Nanofiltration (Nano) systems to allow for real-time monitoring and control of those systems. Remote monitoring is available as an option for new systems, as well as for retro-fit on existing systems.
- Remote Monitoring allows for access from any internet connected device and can be used to track and/or improve system performance, as well as for troubleshooting. Customers are given access to a private network with individual login capability that is password protected.
- Aqua Clear also offers a monitoring service, whereby it will monitor a system to track system trends and alert operators to any potential problems that may be developing and/or potential opportunities to improve the performance of the system. This service is especially beneficial for customers that have limited experience with RO or Nano systems.
- Aqua Clear provides systems to hotels, and commercial operations as well as for power plant cooling and steam. It also works with a spectrum of industries

Evoqua offers Process Monitoring for Filtration and Separation Systems

- The Wallace & Tiernan® Systems Process Monitoring System is an intelligent visualization system with an advanced architecture for data communication and Internet technology.
- This data management system can be used as a simple data acquisition and visualization solution. The Process Monitoring System device automatically creates monthly files for each device that is connected to the bus. These files are updated on a daily basis and can be downloaded via the web interface or copied directly from the memory card. Features include
 - Data visualization using an integrated web server
 - Remote device configuration and maintenance
 - Access only by authorized users
 - Archive files remotely accessible
 - E-mail function for scheduled status reports or event-driven mails triggered by preconfigured alarms
 - Data archiving to memory card



GEA Predictive Maintenance Tools

Predictive maintenance tools are increasingly being used to improve a plant's operation, safety and product quality as well to extend the machine life and achieve higher profitability by minimizing downtime. Reliability-centered maintenance (RCM) is a growing priority for customers as it enables them to identify and prioritize the maintenance required to keep parts working within set operating conditions.

GEA provides the services to meet these new requirements for achieving maximum plant availability with the highest process efficiency and budget control. Individual and combinable service modules; such as condition monitoring, maintenance and repairs, as well as modules for upgrades, modernization or customer training, can be adapted to changed production conditions in each phase of the life cycle – with no additional costs. This means that imminent service actions can be properly planned and potential downtimes can be optimized.

Benefits are

- Individual and combinable service modules for each phase of the entire life cycle
- Demand oriented, customized, adaptive
- Total cost control and budget security
- Maximum plant availability
- Optimized plant performance
- Optimum value retention of investment

Nalco 3D TRASAR

- 3D TRASAR Technology for Membranes detection capabilities provide remote monitoring and alarming of any RO system.
- Experts review, trend and prevent problems 24/7 before they occur – a part of Nalco 360 Service. This means Nalco is truly a Trusted Advisor, a Virtual Operator and a System Manager providing expert recommendations and optimizing membrane system performance.
- 3D TRASAR Technology for Membranes collects operational data for performance analysis, and includes web reporting & data management (with the Nalco Web portal).
- Equipment is customized to handle a variety of reverse osmosis system configurations and can be upgraded as changes are made to operating conditions or process equipment
- 3D TRASAR Technology for Membranes also controls antiscalant dose, but with the added feature of being able to compensate for background fluorescence. pH can also be controlled, and bisulfite addition can be tied to ORP readings to prevent accidental oxidation of the membrane



Advantages of 3D TRASAR

- 3D TRASAR Technology for Membranes delivers unprecedented return on investment, paying for itself quickly through real operating cost savings. Additionally, it reduces your environmental footprint, delivering measurable environmental return on investment...eROI. Through 3D TRASAR Technology, and the normalization, monitoring and control of your RO, performance will be best in class.
- Save water, reduce waste water If your actual recovery is 4% less than design, 3D TRASAR Technology can provide significant benefits in saving water and reducing waste. And remember, most flow meters have an accuracy of +/- 5 %...or worse! Plus, the recovery calculation depends on dividing two flow meter readings, so while you may be reading 75% recovery, the actual may be 68%.
- Minimize impact of poor water quality on final product In many cases, water quality issues can have significant impact on final product, or the production process. With 3D TRASAR Technology, you can proactively head off these issues.
- Operate on different / lower quality feed water Many operations have been able to switch from well to surface water sources and thereby reduce water costs. Also, maintain production when placed under “take-off” restrictions. 3D TRASAR Technology enables this by helping you adjust operation based on water quality.
- Save energy A clean RO system minimizes energy consumption, and 3D TRASAR Technology keeps it that way
- Minimize downtime / maximize availability Lost production associated with unplanned downtime due to membrane fouling or membrane replacement is expensive. With 3D TRASAR Technology, your RO system is continuously controlled to minimize this risk. Decrease cleaning frequency Our experience has shown that you can triple your time between membrane cleanings. Your RO system can go from monthly cleaning to quarterly, and beyond.
- Increase membrane life Experience has shown that membrane life can be doubled, with subsequent cost savings. Imagine extending your membrane life from two years to four years!
- Reduce risk of accidental membrane damage Chlorine damage is a common cause for premature membrane replacement. 3D TRASAR Technology provides a reliable extra layer of protection against accidental chlorine damage to your membranes.
- Control antiscalant dosage 3D TRASAR Automation constantly monitors antiscalant dosage as well as system conditions, assuring that dosage is precisely correct. No costly and useless over-dosing, or potentially damaging under-dosing.

Support Services from Nalco

- Membrane Scheduled Performance Services Preventative maintenance visits to improve productivity and minimize downtime.
- Membrane Cleaning Services Membrane cleaning services using the customer's clean-in-place (CIP) skid. Membrane Replacement Services
- Membrane replacement and installation services.
- Membrane System Consulting & Engineering Services Audits and troubleshooting, as well as system engineering and design services.
- Onsite Membrane Training Services Training services on subjects such as:
 - Basic Water Chemistry
 - Water Analysis Interpretation and General Pre-treatment
 - RO Fundamentals & Basic System Operation
 - Membrane & Intermediate-Level Maintenance
 - RO System Troubleshooting & Advanced System



U.S. Water Program prevents Fouling by determining Key Performance Indicators

- Membrane systems provide significant value to operations by lowering cost of additional water treatment, saving energy in utility operations, or meeting various purity needs for process applications. Membrane systems' impurity removal is further defined by application need and the membrane technology being utilized. Micro filtration (MF) and Ultrafiltration (UF) will effectively remove most suspended solids and bacteria, and other large biologicals. Nano filtration (NF) and Reverse Osmosis (RO) will remove dissolved minerals; but are more susceptible to permanent fouling from larger impurities. Despite their benefits, membrane systems represent significant capital and O&M expense.
- The membrane elements that perform the impurity rejection are one of the largest portions of the system investment, and are prone to fouling at varying rates depending on the quality of the water feeding the system. Properly timed cleaning will prolong the life of the membrane elements, but, if foulants are allowed to build, the impact can be repeated cleanings costing significant manpower and chemical, or in the worst case, a complete replacement of the membranes. Replacement of RO membranes is typically driven by fouling that cannot be cleaned effectively causing higher than desirable mineral passage, decreased flows, or excessive energy usage. Replacement should however be driven by membrane age and expected flux decline.
- For a 100 GPM RO system, the membrane elements represent a roughly \$20,000 investment. Not included in this figure is the manpower for replacement (approx. 12 man-hours) and possible downtime / "impure" water impact. Finally, factor in additional risk to unplanned downtime in operations or negative impact on products and you'll see it is imperative to properly monitor and maintain an RO system.
- The raw data collected by the sensors throughout the membrane system cannot be used directly to determine the performance of the system. RO systems require data to be normalized in order to determine the extent of fouling. The normalized key performance indicators (KPI's) are based on a reference condition and take into consideration variations in conditions that do not impact fouling. Closely monitored, these KPI's can help drive continuous improvement on the RO cleaning process and drive longer term decisions, such as membrane replacement planning

Normalized KPIs Remotely Monitored with U.S. Water SMART

- While the normalized KPI's may be monitored through user input into complex spreadsheets, they can also be monitored remotely with U.S. Water's SMART (Service Maintenance And Routine Treatment) Care™ for Membranes program.
- This program provides monitoring of the membrane system KPI's and notification of their approach to action limits by email. The SMART Care™ program also provides dashboards to your email or on demand providing analysis of all KPI's including calculations of KPI rate of change and projected conditions at dates in the future. The program can be further enhanced by the monitoring of additional KPI's such as pretreatment chemical usage, totalized flow rates, runtimes, recoveries, and cleaning events.
- U.S. Water wraps their integrated offerings around the SMART Care™ program with their comprehensive product line of chemicals, consumable equipment, service, and engineering. Periodic service visits by certified and experienced technicians provide a human element to the program allowing for local review of the program along with verification of all sensors and conditions. SMART Care™ dashboards are reviewed by U.S. Water's engineers periodically to ensure proper performance of the system.
- These reviews can also uncover valuable improvement projects with documented Return On Investment (ROI).



GE Insight analyzes Water Treatment Problems

Water and process applications generate or directly affect vast amounts of operating data that can be chemical, physical or performance in nature. Left unmanaged, these meaningful insights that play an integral part in lowering the total cost of operation, are often unseen and lost. Effective water and process operations depend on data transformed into meaningful and actionable information that enables:

- Visualizing current conditions and their trajectory
- Diagnosing problems and seeing opportunities for improvement
- Alarming on events or trends before they threaten asset production or integrity
- Reporting on key performance indicators and their impact on business objectives

Managing knowledge is paramount to achieving outstanding technical and business results. InSight delivers a user experience focused on simplicity and efficiency. Users receive intuitive and seamless tools, delivering unparalleled functionality. InSight will help you get more in return for every dollar spent in your water and process applications



Insight facilitates Collaboration

- InSight, GE's cloud-based knowledge management platform, provides the means to capture and translate data into valuable information. Ultimately providing the knowledge you need to get the most out of your water or process applications that support production assets, at the lowest total cost of operation. InSight provides:
- Analytics: Seeing, at any point in time, the historical and current performance against success criteria, and the trajectory of future performance; where it's on track, and the weaknesses that need improvement.
- Early Detection: Detecting emerging problems, so that action can be taken now, before a failure is experienced in the future.
- Asset Optimization: Identifying opportunities to optimize the applications to which we are entrusted, that lower the total cost of operations, without sacrificing production performance.
- Safety: Acid leaks, chemical storage tank leaks or chemical overfeed are common occurrences that can be detected before a problem becomes serious.
- Productivity: Helping people get more done with tools that enhance their personal productivity, enabling them to see and do more.
- Collaboration: Communicating ... recognizing that each customer is comprised of different groups of people with different roles, responsibilities and informational needs, and providing each of them with the right information in terms of its content, form and frequency so that it's meaningful and actionable. InSight enables customers to choose the way they manage information with a wide range of functionality



Engine and Turbine Air Inlet Filtration



Gas Turbine Inlet Filter Monitoring is just Part of the Larger Package

- Remote monitoring of gas turbines is extensively covered in an industry section. Part of the monitoring is the determination of pressure loss across the filter which is classified as recoverable in that the filter can be changed without lengthy shutdowns
- Recoverable and Non-Recoverable Degradation: An important distinction when monitoring performance is the difference between recoverable and non-recoverable degradation, which is defined as follows:
 - Recoverable Degradation is the performance loss that can be recovered by operational procedures such as keeping the inlet and outlet pressures low, or online and offline water washing of the compressor.
 - Non-Recoverable Degradation is the performance loss that cannot be recovered without repair or replacement of affected gas turbine components. Examples of non-recoverable degradation include: loss of surface finish on blades, increases in blade tip clearances, packing leakage of both the compressor and turbine, and combustion system component corrosion/erosion leading to flame instabilities or increased thermal stress on the subsequent turbine sections. Limited instrumentation inside the engine generally means that locating the actual stage where a significant change in performance has occurred will be difficult or impossible; however, the thermodynamic model will generally be able to flag a severe problem early enough to prevent larger damage.
- One consideration is that a lower efficiency inlet filter may cause a non recoverable degradation.

Gas Turbine Inlet Filter Monitoring is Important

- Continuous monitoring of equipment performance and stringent maintenance regimes can increase the life cycle of the gas turbine as well as ancillary equipment. AAF is one of the companies providing remote monitoring and support for inlet filters.
- AAF maintenance packages can include regular inspections and in-depth site surveys by qualified engineers, air quality guarantees, materials and design analysis, failure modes and effects analysis, remote monitoring, inventory management (filter and spares), and in situ or factory repairs to OEM standards.
- Mcilvaine has several services with details on selection and maintenance of GT filters. They include
 - [4S01 Berkshire Hathaway Energy Supplier and Utility Connect](#)
 - [44I Coal Fired Power Plant Decisions](#)
 - [59D Gas Turbine and Reciprocating Engine Decisions](#)



Food Processing



Market Potential for IIoT in Food and Beverage

- The growth in processed foods is higher than GDP
- Many food processes are dependent on filtration and separation for product quantity and quality
- New food processes are driving innovation in filtration and separation
- The world food and beverage filtration industry is several billion dollars per year
- Beer and soft drinks are the biggest segments followed by dairy.
- IIoT will be widely used in food and beverage processing in the future
- A number of large companies have both food filtration and IIoT activities and can leverage them

Granular Breakout of Filtration Revenue by Type, within Industry, Mil \$

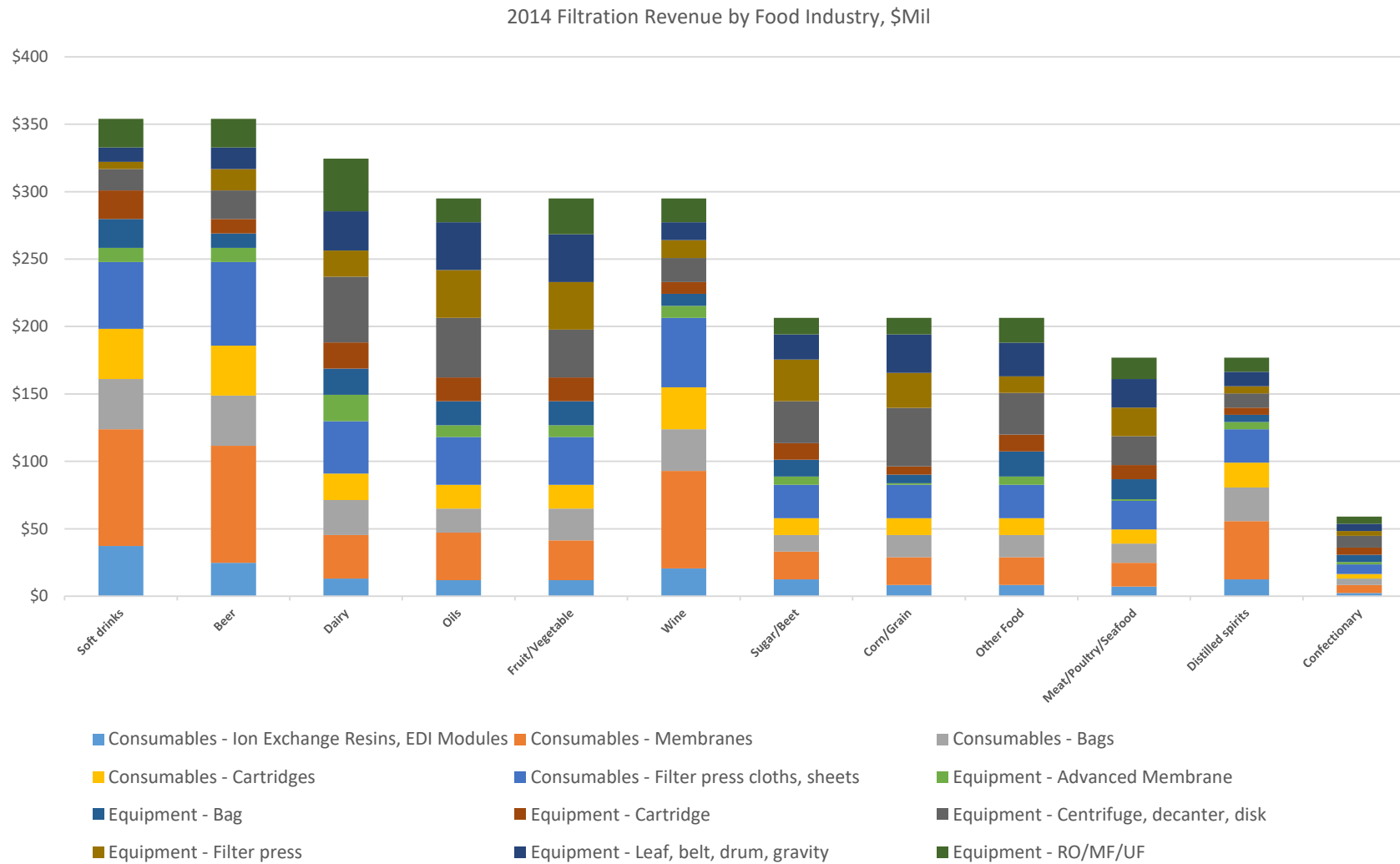

Companies which can Leverage Multi Divisional Activities to build IIoT in Food Filtration and Separation

- Alfa Laval - supplies complete food processing systems and is leader in centrifuges
- Andritz – supplies complete plants and has a wide range of filtration and separation products
- Danaher- can build around Pall
- Eaton- has small but active food filtration group and the wide range of electrical IIoT activities

Alfa Laval

Filtration and separation

Large global market share
for separators, all
industries



Separation
25-30% market share

Separation



Separate fluids, solids and gases with outstanding precision and low running cost. Based on proven technology with a reputation for reliability in industries such as food, pharma, chemical, oil and wastewater treatment.

- ▶ Decanter centrifuges
- ▶ Membrane filtration
- ▶ Filters and strainers
- ▶ Separators



Disc-stack centrifuges



Decanter centrifuges



Spiral membrane

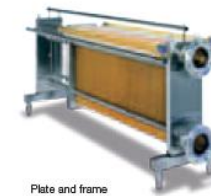

Plate and frame membrane (LWT)



Separator module for beverages



Decanter module for juice extraction from fruit and vegetables



Membrane module for product concentration



Yeast propagation module



Tank top system



Complete flow battery at protein processing plant, Germany



Decanter based wet rendering system for soft fatty tissues, USA



Complete mango processing plant, India



Decanter system for grape juice extraction, France

Andritz

A complete range
for all your food separation needs

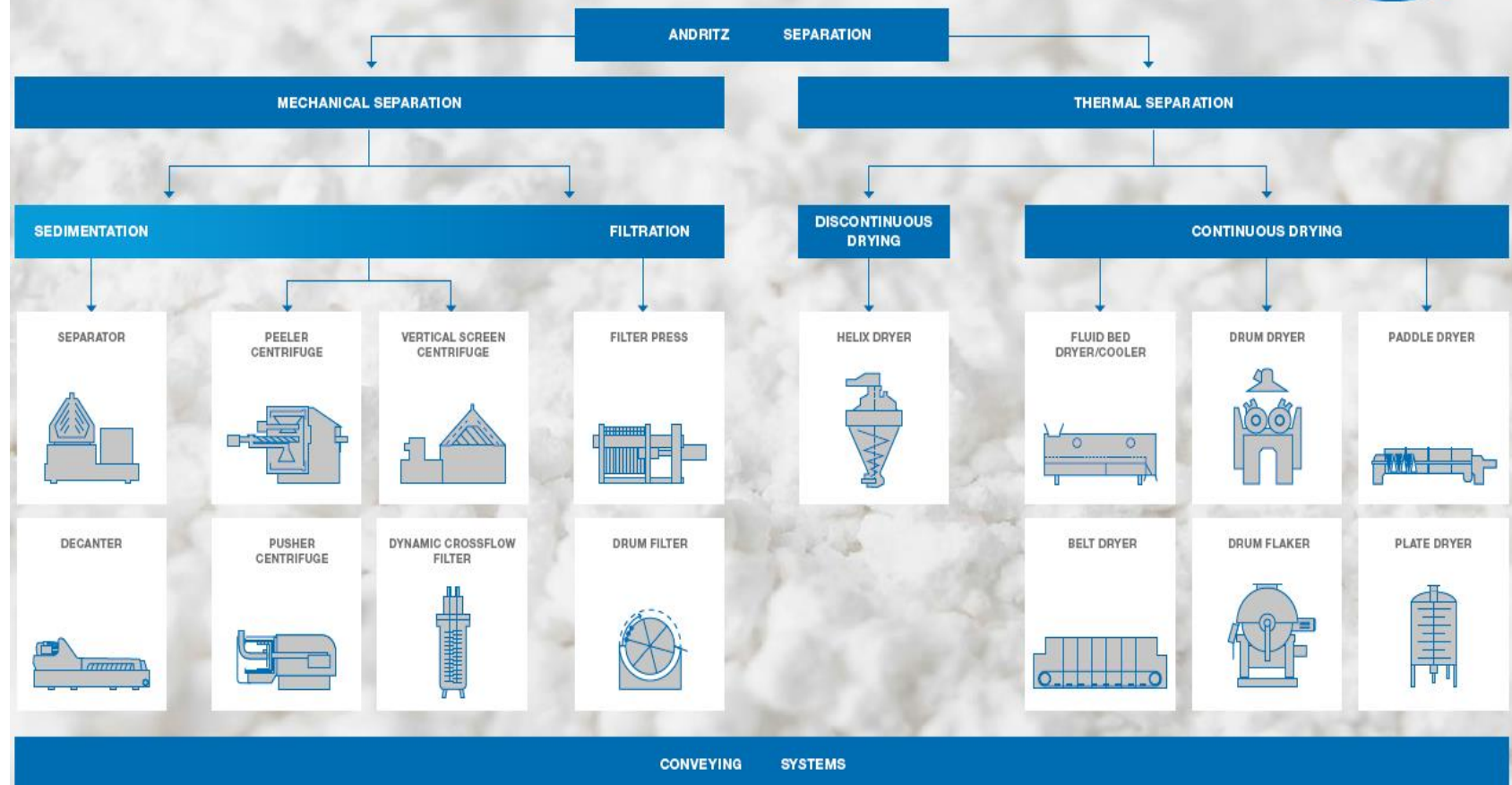

CONVEYING SYSTEMS

Danaher can leverage Pall Knowledge

The opportunity facing Danaher comes from embedding more software in its equipment, thereby spurring increased consumables sales and keeping customers engaged with Danaher's services. Moreover, analyzing data from customer usage of equipment can create valuable opportunities for the company to modify its customer offerings.



Danaher's Opportunity

	Revenue	Recurring Revenue*
Water Quality	\$2.0B	55%
Product ID	\$1.6B	40%
Life Sciences	\$2.5B	50%
Diagnostics	\$4.9B	80%
Pall	\$2.8B	75%
Dental	\$2.8B	60%
Danaher	\$16.5B	60%

All revenue figures are aggregate for FY 2015E.
*As a percent of 2015E sales.

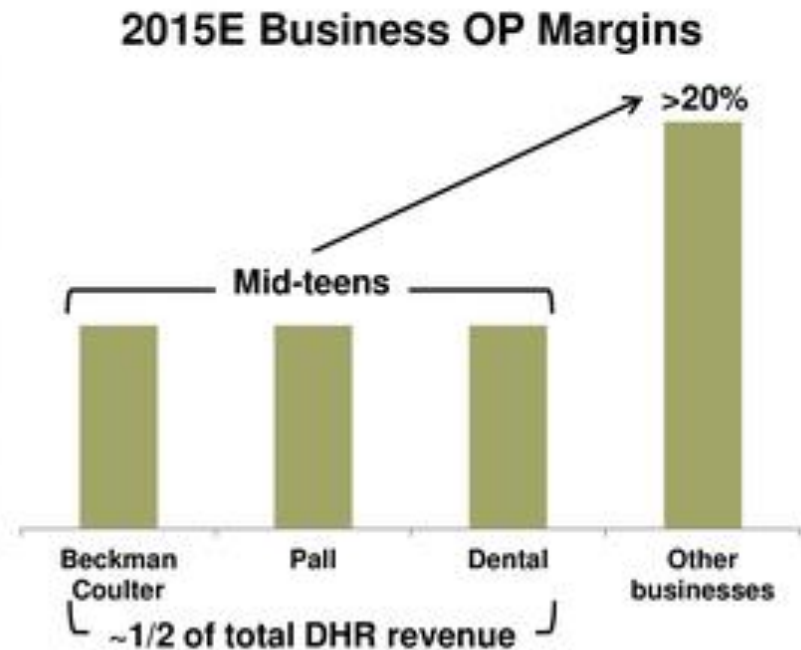

United by resilient business models with significant room to improve through DBS



Pall

Food & beverage market/
application breakouts on website:

- Bottled Water
- Dairy
- Distilled Spirits
- Food and Ingredients
- Breweries (Micro, Corporate)
- Soft Drinks
- Wine Filtration

F&B Filtration Product include:

- Cartridges and Elements (56)
- Coalescers (2)
- Filter Housings (40)
- Hardware (1)
- Media (1)
- Membranes and Materials (1)
- Modules (11)
- Services (6)
- Sheet Filters and Modules (17)
- Systems (27)

Food & Beverage part of Life Sciences segment

- Consumables 91% of Life Sciences sales
- F&B product sales \$185m, 6.6% of Total Company revenue in 2014
- F&B consumables up 6% in 2014 over previous year
- Principal competitors in F&B market include 3M Purification, Pentair, Filtrox, Sartorius, Eaton and Parker Domnick Hunter

Pall Life Sciences: \$1,454

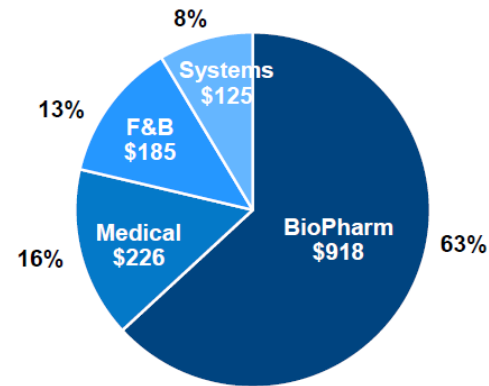

BioPharmaceuticals
Process
Process Monitoring
Laboratory Research

Medical
OEM Healthcare
Hospital/Consumer
Infection Control

Food & Beverage
Alcoholic Beverages
Alcohol-free Beverages
Food & Dairy
Food Safety

Pall Industrial: \$1,335

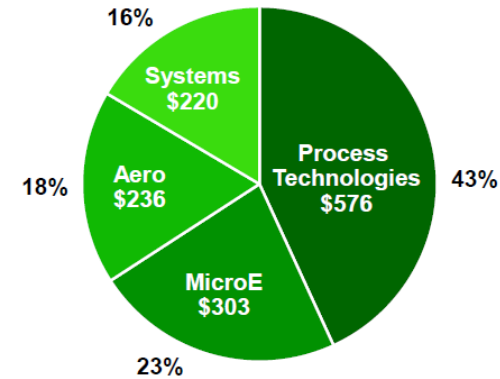

Process Technologies
Fuels & Chemicals
Power Generation
Machinery & Equipment
Water Processing

Aerospace
Commercial Aero
Military Aero
Marine

Microelectronics
Semiconductors
Electronic Components
Data Storage/Displays
Graphic Arts





Food & Beverage Strategy

- Geographic expansion
- Food safety / quality control
- Technology extension
- Dairy
- Continuous processing



Beer
Changing the game



Eaton Range of Filtration Equipment and Consumables for Food and Beverage

- Filters for Food & Beverage processes
- Mechanically Cleaned Industrial Filters:
- MCF Magnetically Coupled Industrial Filters
- DCF Self-Cleaning Filters
- Tubular Backwashing Industrial Filters:
- AFR Tubular Backwashing Filters
- Replaceable Media Pressure Industrial Filters:
- Filter Bags
- Filter Housings
- Depth Filtration:
- Depth Filter Sheets
- Depth Filter Capsules
- Stacked Disc Cartridges
- Filtration Systems



Eaton focusing on IIoT

- Frank Campbell, Eaton's President, Corporate and Electrical Sector, Europe, Middle East and Africa (EMEA), said: "Eaton is a global company with more than 100 years of history in the US and Europe. We look forward to bringing that historical expertise to host discussions around the most up-to-date trends such as the industrial Internet of Things and the need for more efficient energy storage solutions. Eaton has an extensive product portfolio that will help underpin the digitization of the manufacturing environment in international markets, leading to smarter and more efficient production."

Eaton has Electrical Sales of \$12 billion

- Eaton's Electrical Sector and Hydraulics Group engineers are actively looking at integrating the IoT across a growing number of products. By capturing data that exists within components and systems and making it available, these products will be able to provide actionable knowledge to improve performance.
- Eaton's Yukon Advanced Energy Services Platform provides utilities with smart metering technology to help develop smart grid capabilities. Moreover, its GridAdvisor smart sensors also help utilities with the necessary machine-to-machine communications.
- The company's Metalux Encounter and SkyRidge integrated lighting solutions can switch on and off based on occupancy and dim automatically depending on available daylight.
- 2016 4th quarter Sales for the Electrical Products segment were \$1.7 billion, flat compared to the fourth quarter of 2015. Organic sales were up 1 percent and currency translation was negative 1 percent. Operating profits, excluding acquisition integration charges of \$1 million during the quarter, were \$317 million, up 4 percent over the fourth quarter of 2015.

Sales for the Electrical Systems and Services segment were \$1.5 billion, down 3 percent from the fourth quarter of 2015. Organic sales were down 2 percent and currency translation was negative 1 percent. Segment operating profits were \$177 million, down 15 percent from the fourth quarter of 2015, with the decline driven by restructuring costs of \$29 million in the fourth quarter of 2016 versus \$3 million in the fourth quarter of 2015.

Eaton has Smart Circuit Breakers

- Eaton is collaborating with the Electric Power Research Institute (EPRI) and Electric Imp to create the breakthrough, “smart” and secure circuit breakers.
- EMCBs deliver insight and control of high power usage devices to utilities in an incredibly easy to install form factor: a standard breaker. Being able to monitor – and where necessary, control – individual high current circuits behind a subscriber’s main meter allows the utilities unprecedented flexibility in managing these loads. This ensures they can deliver a high quality, reliable service whilst incorporating renewables, energy storage, and new loads such as electric vehicle chargers into the grid.
- Eaton is using Electric Imp because it meets their three core requirements - security, reliability and scalability. Electric Imp’s platform is protected by impSecure™ managed security services, which provide security from silicon to the cloud, and maintenance throughout the lifetime of the EMCB. The data is quickly integrated with analytics tools from Eaton, EPRI and/or the utility’s chosen enterprise applications and big data systems.
- Connecting the EMCBs quickly and easily is crucial for the utilities. The EMCB installation process uses BlinkUp™ and a custom mobile application to collect metadata about the installation - including location, photos both pre and post install, and other details - and tie this securely and seamlessly to the commissioned device in a single step.

Eaton Lighting Activities can also be Leveraged

- In lighting, the development of intelligent lighting controls and digital communication architectures allowed networkable lighting. The miniaturization of microprocessors enabled intelligence to be embedded in lamps and luminaires. Digital communication enabled remote programming and the collection of data used for energy analysis and maintenance. These controls are inherently compatible with light-emitting diode (LED) lighting, which is also digital.
- More recently, capabilities such as the cloud, coupled with growing interest in intelligent building operation and Big Data, have accelerated the development of the Industrial Internet of Things (IIoT). By deploying intelligence throughout a building, it becomes much more responsive. Sensors feed responsiveness while generating valuable data.
- Lighting will play a part in the IIoT, but it has another valuable role. The conversion of traditional lighting to LEDs presents an opportunity to use LED luminaires as infrastructure for IIoT delivery.
- The installation of the luminaires is not directly affected by IIoT implementation,” said Joe Bokelman, marketing manager, Eaton’s Lighting Division. “With a factory-prewired system, there is only a single connection to make. The additional effort comes in coordination of the commissioning of the systems, and
- obtaining and executing the control intent of the system as a whole. Interaction with the owner’s IT managers may also be required to complete IIoT deployment. All of these activities will require new skill sets for electricians, foremen, project managers and estimators



Eaton has Intelligent Valves as Well

- Intelligent valves improve hydraulic power management. Eaton's AxisPro servo performance proportional valves, which are configurable using Eaton's Pro-FX Configure software, offer high dynamic performance, enabling them to be used in closed-loop applications, says Per Danzl, product manager for Eaton's Industrial Portfolio. AxisPro valves feature embedded pressure and temperature sensors, field bus communication capabilities, and intelligent on-board diagnostics to help predict maintenance issues.